

Screw type flow meters
SVC



KRACHT®
FLUID TECHNOLOGY AND SYSTEMS

Content

Construction Function General product characteristics Approvals	4
Sensor versions	5
General characteristics Accuracy characteristics	6
Technical data	7 - 8
Type key	9
Electrical connections Signal characteristics	10
Electrical characteristics	11
IO-Link	12
Explosion-proof design variant (ATEX/IECEX)	13
Pressure drop charts	14 - 15
Technical drawings overview	16
Technical drawings (dimensions/weights)	17 - 24

Description

I Construction

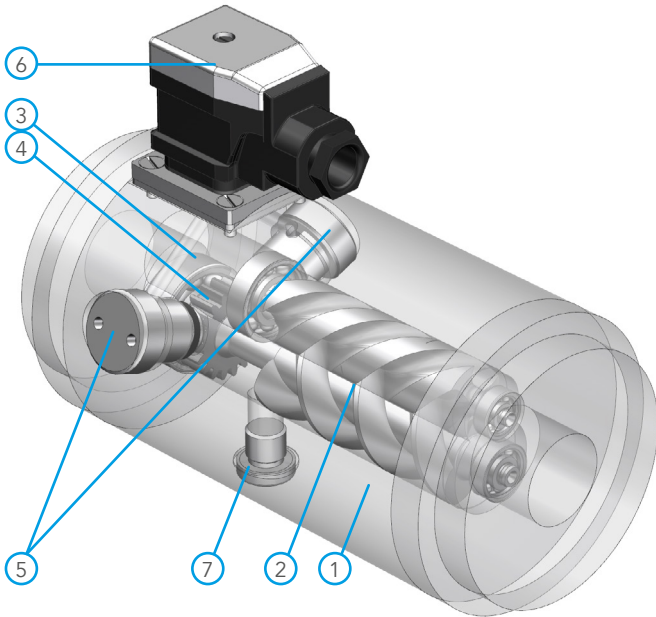

- 1 Housing
- 2 Measuring system (screw spindles)
- 3 Bearing (ball bearings)
- 4 Sensing wheel
- 5 Sensors
- 6 Plug
- 7 Measuring connection (pressure, temperature, etc.)

I Product characteristics

- High-precision measurements with excellent repeatability
- Pulsation-free measuring principle
- Maximal measurement resolution if used with encoder
- IO-Link technology available
- Wide measurement ranges with appropriate design sizes
- Application-optimised specification
- Very low pressure drop
- Any flow direction (see preferred direction of encoder versions)
- Wide temperature range
- High working pressure
- Very low noise
- Highly-dynamic measurements
- Explosion-proof versions ATEX/IECEx
- Electronics in EMV-compliant version
- RoHS-compliant

I Function

Two high-precision screw spindles (2) with rolling-element bearings (3) for low friction. The liquid flow makes the spindles rotate (displacement principle) and runs through the device in axial direction. Flow in and out takes place without hardly any deflection, which means the device only loses comparatively little pressure. The measuring principle does not cause any pressure or volume flow pulsation. Because there is no need for settling sections on the inlet and outlet side, machines/plants can be designed to be more compact. All moving parts are lubricated by the measuring medium.

The spindle-mounted sensing wheel is scanned by two contact-free sensors by default. The plug is equipped with a pre-amplifier that converts the sensor signal into a square-wave signal which serves as output signal. The dual-channel scanning facilitates a higher measuring resolution and detection of the direction of flow. Alternatively available encoder specifications deliver maximal measurement resolution.

I Approvals

	Description	Country
	EU compliance – EMV – Pressure equipment – RoHS	European Union
	EAC EMV guideline	Eurasian Economic Community
	GOST metrology, measurement technology	Russia
	IO-Link	International

Description

I Standard version



The standard versions come with an integrated pre-amplifier which converts the pulses from the magnetic sensors into square-wave signals which are then computed by an electronics into specific measurement values.

The optionally available remote-electronics version is designed to handle extreme temperature ranges.

I Encoder version with maximised measurement resolution



Compared with standard sensors, encoders are capable of generating considerably more pulses, thus increasing measurement resolution by orders of magnitude. Encoder-equipped SVC flow meters generate up to 2 500 pulses per revolution and can recognise the direction of flow.

Encoders, like the standard versions, send square-wave signals to the electronics.

I IO-Link version with internal calculation of measured values



SVC flow meters with IO-Link technology are based on standard SVCs with two sensors. Unlike the versions with pre-amplifier which always send a square-wave signal to the electronics, IO-Link devices have the added capability of internally computing concrete measurement values. Therefore, these flow meters lend themselves for use in classic PLC and in IO-Link infrastructures.

Please see page 12 for details.

Technical data

I General characteristics

Nominal sizes	4 · 10 · 40 · 100 · 250	
Type of connection	Pipe connection (R), SAE flange (S), DIN flange (D)	
Mounting position	Any	
Flow direction	Any	
Preferred direction of flow (only for encoder versions)	Large bearing > small bearing	
Typical measurement accuracy	+/- 0.2 % from 20 mm ² /s viscosity values	
Maximum pressure (standard versions)	SVC 10	250 bar
	SVC 40	250 bar
	SVC 100	140 bar
	SVC 250	40 bar
Maximum pressure (high-pressure versions)	SVC 4	480 bar
	SVC 10	480 bar
	SVC 40	480 bar
Maximum permissible pressure loss	Temporary	25 bar
	Permanent	7 bar (at 50 % of max. flow rate)
	SVC 100 (ATEX version)	10 bar
Ambient temperature	-40 ... 150 °C	
Media temperature	-40 ... 210 °C	
Viscosity	... 2 500 000 mm ² /s (depending on flow)	
Sound pressure level	... 52 dB(A)	

I Accuracy characteristics

- The indicated measurement accuracy refers to the pulse volume, i.e. the percentage variance applies to the latest measurement value.
- The measurement accuracy is up to +/- 0.2 % of the measured value by default.
- Repeatability is +/- 0.05 % in stable conditions.
- The measurement accuracy tests performed can be traced to DAkkS (Deutsche Akkreditierungsstelle, German Accreditation Body).
- The measurement accuracy characteristics indicated by KRACHT is confirmed by DAkkS.
- A calibration is possible on request. The result of this calibration will be documented in the form of a measurement accuracy characteristic.

Typical measurement accuracy characteristic

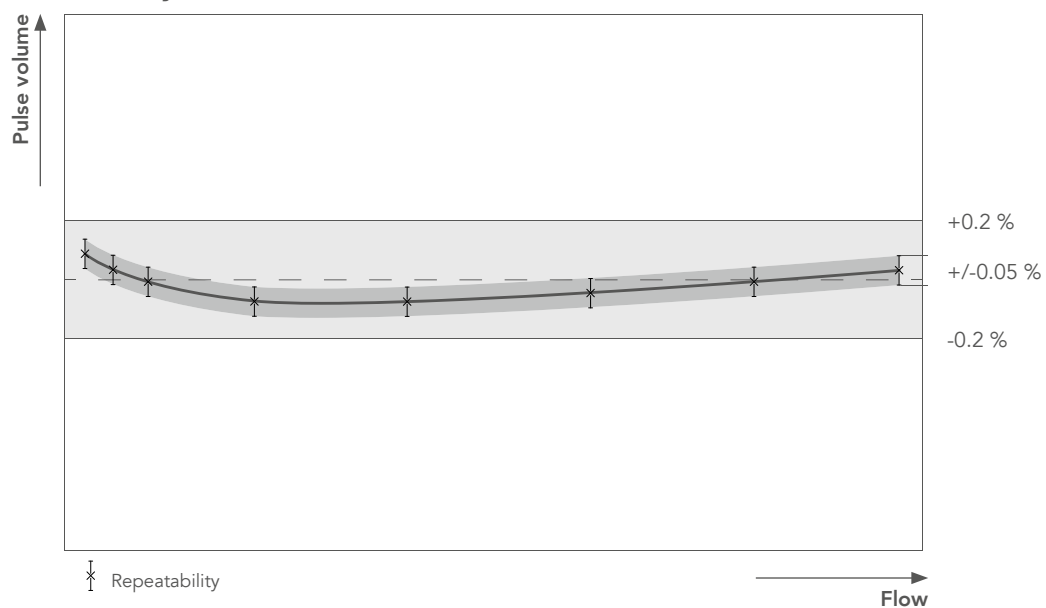

Technical data

I Materials

Housing and flanges	EN-GJS-400-15 (GGG-40)
Measuring spindles	Heat-treated steel
Ball bearing	Heat-treated steel
O-ring	FKM, EPDM, FEP, FKM low temperature

I Sealing elements and electronics temperature tolerance

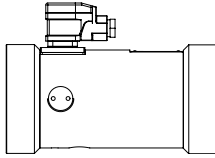
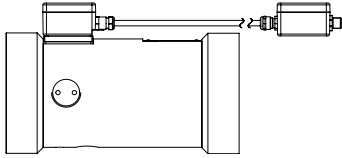
Versions with integrated electronics	Versions with remote electronics
<p>Versions with appliance socket (Hirschmann) T_{amb} = -40* ... 80 °C</p> 	<p>T_{amb} = -40* ... 150 °C -40 ... 80 °C</p> 

Electronics versions	Standard	High-temperature	ATEX version	IO-Link	Without pre-amplifier	Encoder	High-temperature PLUS	ATEX version high temperature PLUS
Type key ID	S	H	X	L	V	E	K	KX
Sealing material	Medium temperature in °C							
FKM	-30 ... 120	-30 ... 150	-15 ... 80	-40 ... 120	-15 ... 80	-		
EPDM		-	-30 ... 80		-20 ... 80	-		
FEP		-30 ... 150	-30** ... 80		-30 ... 210	-30** ... 180		
FKM low temperature	-40 ... 120	-40 ... 150	-	-	-	-40 ... 150	-15 ... 200	

* For ATEX/IECEX: T_{amb} min FKM = -15 °C
 T_{amb} min EPDM = -30 °C
 T_{amb} min FEP = -30 °C**
 T_{amb} min FKM low temp. = -15 °C

** Devices produced up to and including 2019 can be used at temperatures of up to -15 °C

Technical data

I Standard versions characteristics

Nominal size	Pulse volume	Resolution	Resolution 4-fold*	Pulse frequency with Q_{max}	Measuring unit starting at		Measuring range
					Horizontal mounting position	Vertical mounting position	
	cm ³ /pulse	pulse/l	pulse/l	Hz	l/min	l/min	l/min
10	1.4180	705.20	2,820.9	1,763	0.05	0.02	1.0 ... 150
40	5.1300	194.90	779.7	1,950	0.10	0.02	4.0 ... 600
100	9.8200	101.80	407.3	2,546	0.15	0.03	10.0 ... 1,500 10.0 ... 1,000 (ATEX version)
250	18.2500	54.80	219.2	3,425	0.90	0.06	25.0 ... 3,750

I High-pressure version characteristics

Nominal size	Pulse volume	Resolution	Resolution 4-fold*	Pulse frequency with Q_{max}	Measuring unit starting at		Measuring range
					Horizontal mounting position	Vertical mounting position	
	cm ³ /pulse	pulse/l	pulse/l	Hz	l/min	l/min	l/min
4	0.2550	3,921.60	15,686.3	3,921	0.03	0.01	0.4 ... 60
10	0.7085	1,410.44	5,641.8	3,534	0.05	0.02	1.0 ... 150
40	5.1300	194.90	779.7	1,950	0.10	0.02	4.0 ... 600

* Resolution with both measuring channels and 4-fold evaluation

I Encoder versions characteristics

Nominal size	Sensor resolution*	Pulse volume	Resolution	Measured value resolution 4-fold**	Pulse frequency at Q_{nom}	Measuring unit starting at		Measuring range
						Horizontal mounting position	Vertical mounting position	
	pulse/rev	cm ³ /pulse	pulse/l	pulse/l	Hz	l/min	l/min	l/min
10	512	0.078926	12,670	50,681	21,117	0.05	0.02	1.0 ... 150
10	2,500	0.016164	61,866	247,463	103,110			

* More sensor resolutions available on request

** Resolution with both measuring channels and 4-fold evaluation

Type key

SVC	10	K	1	F	1	R	2	S	H
1	2	3	4	5	6	7	8	9	11

1 Product					
2 Nominal size					
4		10		250	
3 Bearing					
K			T		
Ball bearing			FKM cupsuled ball bearing (only nominal sizes 4 and 10)		
4 Material					
1			3		
Standard version Housing spheroidal cast iron GJS-400 / spindles steel			High-pressure version (higher resolution) Housing spheroidal cast iron GJS-400 / spindles steel		
5 Sealing					
F		E		P	
FKM		EPDM		FEP	
				L	
				FKM low temperature	
6 Surface					
1		2		3	
Standard (coated)		Coating Skydrol-resistant		Without coating	
7 Connection type					
R		S		D	
Pipe connection		SAE		DIN	
8 Sensors					
2	2 sensors				
5	Encoder (only nominal size 10)				
9 Electronic version (pre-amplifier)					
		Voltage	Media temperature	Conversion	Note
S	Standard	24 V	-40 ... 120 °C	internal	
H	High temperature	24 V	... 150 °C	internal	
K	High temperature PLUS	24 V	... 210 °C	external	
X	ATEX/IECEX (isolating switching amplifier to be ordered separately)		... 80 °C	internal	Pos. 11: only with H
KX	ATEX/IECEX High Temperature PLUS		... 200 °C	external	Pos. 11: only with V
L	IO-Link	10 ... 30 V	... 80 °C	internal	
V	Without pre-amplifier		... 120 °C		
E	Encoder (only nominal size 10)	11 ... 30 V	... 100 °C	internal	
10 Cable length					
Without cable between flow meter and electronic		2 With 2 m cable		5 With 5 m cable	
				10 With 10 m cable	
11 Electrical connection (plug and pre-amplifier case)					
H	Appliance socket (Hirschmann)	standard			
M	Appliance socket (Hirschmann)	with M12x1 4-pole connection			
C	Aluminium connection box	with Cannon plug KPTC			
V	Without				
512	Encoder with 512 pulse/rev	with M12x1 4-pole connection			
2500	Encoder with 2500 pulse/rev	with M12x1 4-pole connection			

Electronics

I Electrical connections

Standard and high-temperature versions

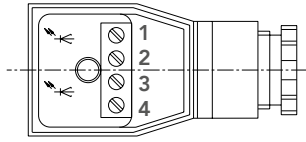

1: U _B (brown)
2: Channel 1 (green)
3: Channel 2 (yellow)
4: 0 Volt (white)

High-temperature PLUS and low-temperature version

Connection plug arrangement (M12x1 4-pole round connector)

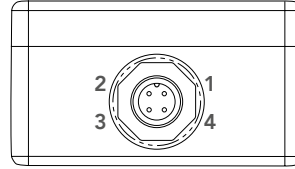

1: U _B (brown)
2: Channel 1 (white)
3: 0 Volt (blue)
4: Channel 2 (black)

Encoder version

Connection plug arrangement (M12x1 metal/4-pole round connector)

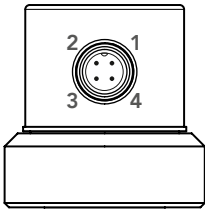

1: U _B
2: Channel 1
3: 0 Volt
4: Channel 2

Cannon version

Connection plug arrangement

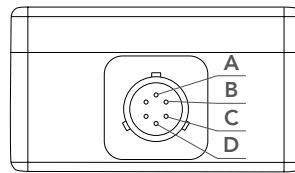

A: U _B (brown)
B: Channel 1 (green)
C: Channel 2 (yellow)
D: 0 Volt (white)

IO-Link version

Connection plug arrangement (M12x1 metal/4-pole round connector)

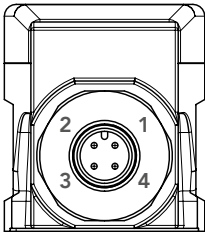

	IO-Link mode	SIO mode
1: brown	U _B	
2: white	I/Q	Channel 1
3: blue	0 Volt	
4: black	C/Q	Channel 2

I Signal characteristics (standard, high-temperature, encoder, IO-Link versions in SIO mode)

The pre-amplifier generated square-wave signal enables application specific resolutions. Standard resolution means that the electronics will process one pulse from a channel/sensor per cycle time (rising signal edge in channel I). In contrast, the 4-fold evaluation uses the maximal pulse rate per cycle time, allowing for a resolution that is four times as high as in the standard evaluation. All characteristics of the signal (rising and falling signal edge of both sensors/channels) are exploited in the evaluation.

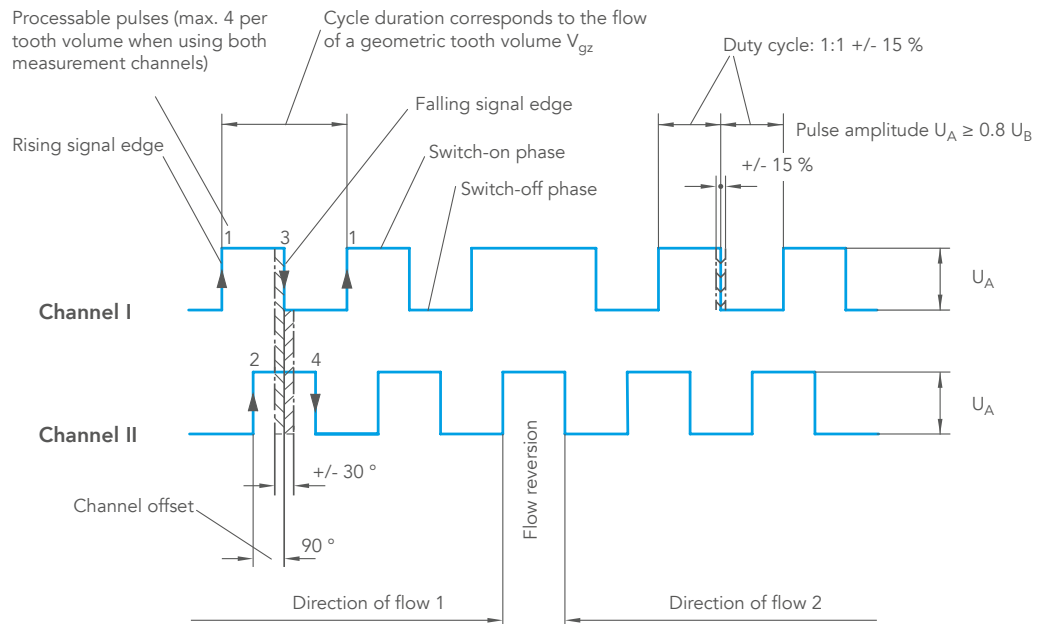

Electronics

I Standard versions electrical characteristics

Number of measuring channels	1 or 2
Working voltage U_B	24 V +/- 20 % or 12 V +/- 20 % for versions with reduced supply voltage
Pulse amplitude U_A	$\geq 0.8 U_B$
Pulse with symmetric output signal	Square duty factor/channel 1:1 +/- 15 %
Signal output	PNP / NPN
Pulse offset between the two channels	90 ° +/- 30 °
Power requirement $P_{b \max}$	0.9 W
Output power / channel $P_a \max$	0.3 W short circuit-protected
Protection rating	IP 65

I Encoder versions electrical characteristics

Number of measuring channels	2
Working voltage U_B	11 ... 30 V
Pulse amplitude U_A	$\text{Min}_{\text{High}} \geq U_B - 3 \text{ V}$ $\text{Max}_{\text{Low}} \leq 2,5 \text{ V}$
Pulse shape with symmetric output signal	Square , Duty factor/channel 1:1 +/- 15 %
Signal output	Push-Pull
Pulse offset between both channels	90 ° +/- 30 °
Maximum load	+/- 30 mA
Power consumption	Standard 45 mA Maximum 150 mA
Protection rating	IP 65

I IO-Link versions electrical characteristics

	IO-Link mode	SIO mode
Number of measuring channels	1 or 2	
Working voltage U_B	10 ... 30 V	
Pulse amplitude U_A	$\text{Min}_{\text{High}} \geq U_B - 2 \text{ V}$ $\text{Max}_{\text{Low}} \leq 2 \text{ V}$	
Pulse shape with symmetric output signal	-	Square duty factor/channel 1:1 +/- 15%
Signal output	active pull +/- 200 mA	
Pulse offset between the two channels	-	90 ° +/- 30 °
Power requirement $P_{b \max}$	1 W	
Protection rating	IP 65	

Electronics

I IO-Link general

Thanks to its international standardisation (IEC 61131-9), the IO-Link technology offers a point-to-point connectivity with continuous monitoring between any desired control layer and the SVC-IO-Link assembly. Handling and startup is made easy by the associated IODD file (IO Device Description) strongly simplified

The SVC-IO-Link assembly directly delivers all measured values with units. In the preset SIO mode (standard input output), the volume counter gives square-wave signals if the IO-Link mode is not enabled by an IO-Link master. This guarantees downward compatibility of the SVC-IO-Link assembly with the standard square-wave signal (see page 10).

I IO-Link connection plug

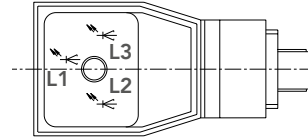

	IO-Link mode	SIO mode
L1 green	Flashing at 1/s	Continuous light, ready for operation
L2 red	Channel 1	gear detected = LED on gear not detected = LED off
L3 red	Channel 2	gear detected = LED on gear not detected = LED off

I IO-Link characteristics

Name	SVC
Manufacturer ID	0x0524
Device ID	0x000001
Name of manufacturer	Kracht GmbH
IO-Link connection plug	V1.1
Bit rate	COM3 / 230.4 kbit/s
Minimum cycle time	500µs
SIO mode supported	Yes
Use of indexed service data (IS DU)	Yes
Data storage (DS) possible	Yes

I Communication of the IO-Link assembly

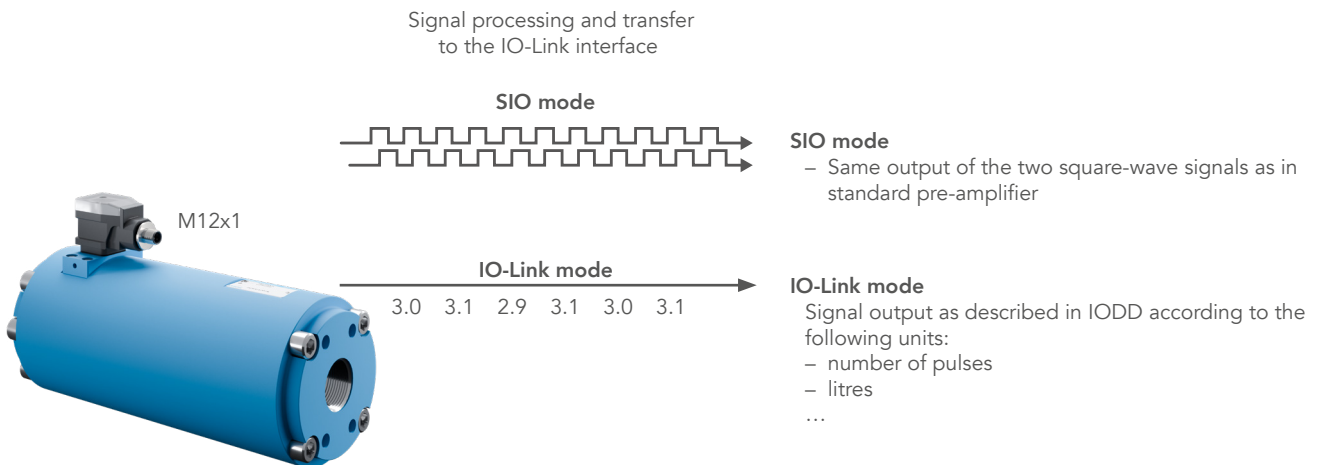

Explosion-proof version (ATEX/IECEX)

I Function

- All screw type flow meters are available as explosion-proof versions according to ATEX and IECEx certification.
- The explosion-proof version consists of the flow meter (intrinsically safe electric gear) and the switching amplifier K 130 (accessory electric gear). This layout meets the ignition protection type "intrinsic safety".
- The flow meter is installed in the explosive atmosphere.
- The switching amplifier K 130 is assembled in the safe atmosphere.
- The flow meter is electrically connected with the switching amplifier. The switching amplifier analyses the sensor signals coming from the flow meter and converts them into square-wave signals.
- It is prohibited to deploy the flow meter in explosive atmospheres without switching amplifier.
- The cable between the flow meter and switching amplifier may be up to 400 m long.
- The switching amplifier features LEDs to monitor for line breakage / short circuit, channel switching state, and voltage supply.

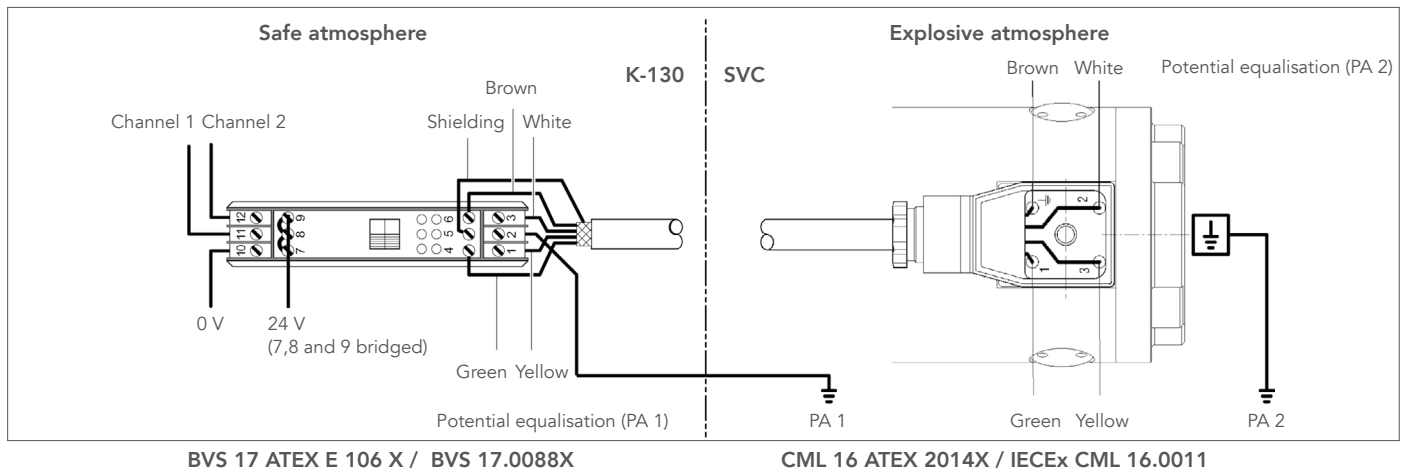

Notes

This drawing only serves as an example for the connection of the sensors to the isolating switching amplifier K 130. Observe the applicable standards when assembling a plant in an explosive atmosphere.

Ignition protection marking (device-dependent)

⊕ II 2G Ex ia IIC T4 Gb

⊕ II 2D Ex ia IIIC T135 °C Db

I Switching amplifier K-130 technical characteristics

Supply	
Supply voltage terminal 7 (L+), terminal 10 (L-)	DC 24 Volt +/- 20 %
Output (not intrinsically safe / nominal data terminals 9, 12, 8, 11)	
Electronic outputs	Electrically isolated via photocoupler
Signal level 1-signal	Output voltage > 15 V
Signal level 0-signal	Output voltage ≤ 5 V
Ambient conditions	
Low threshold temperature	248 K (-25 °C)
High threshold temperature	333 K (+60 °C)
Mechanics	
Dimensions	114.5 x 99 x 22 mm
Mounting	Can be snapped on to 35 mm sectional rail, DIN EN 60715

Pressure drop

I SVC 4 ... 40 Parameter: Viscosity in mm²/s

SVC 4

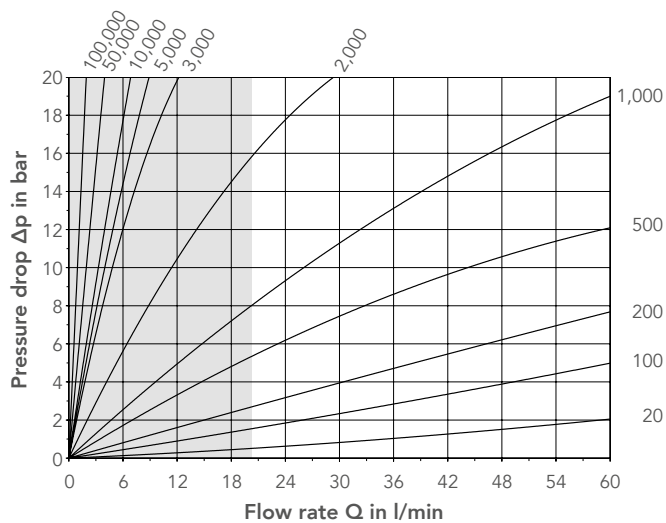

SVC 4 (section)

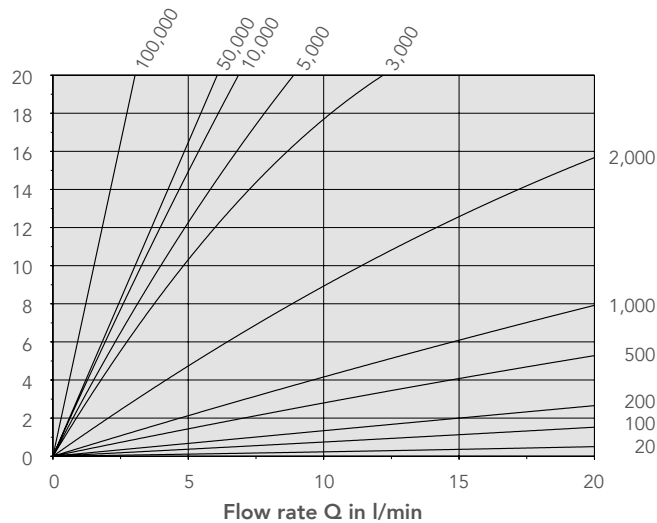

SVC 10

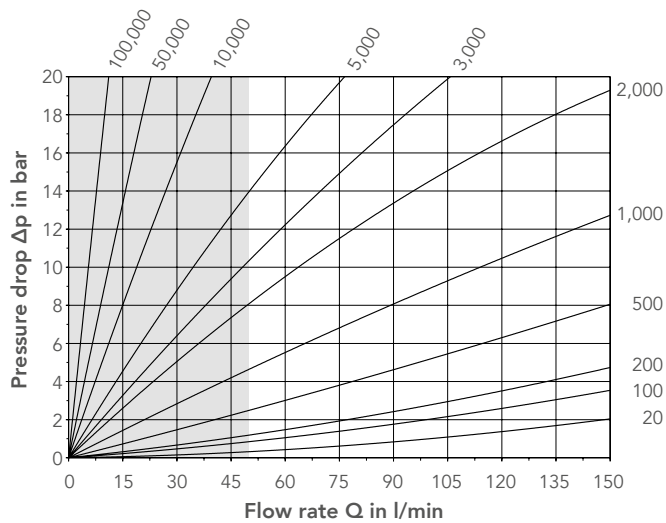

SVC 10 (section)

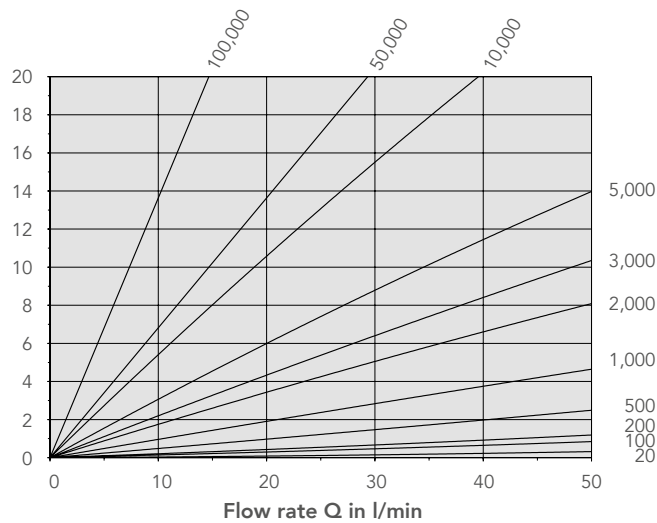

SVC 40

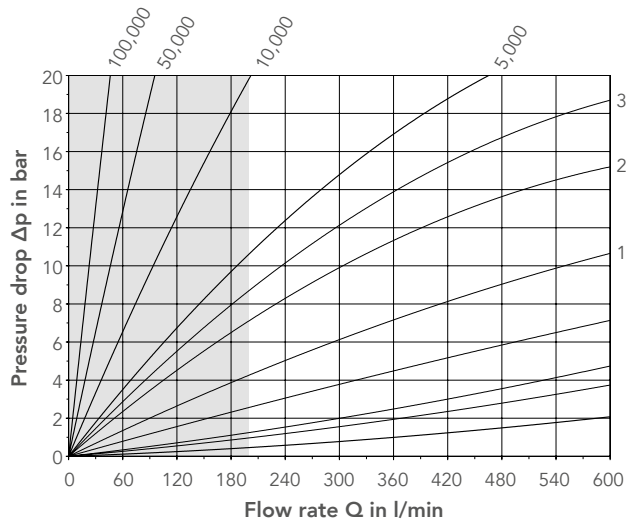

SVC 40 (section)

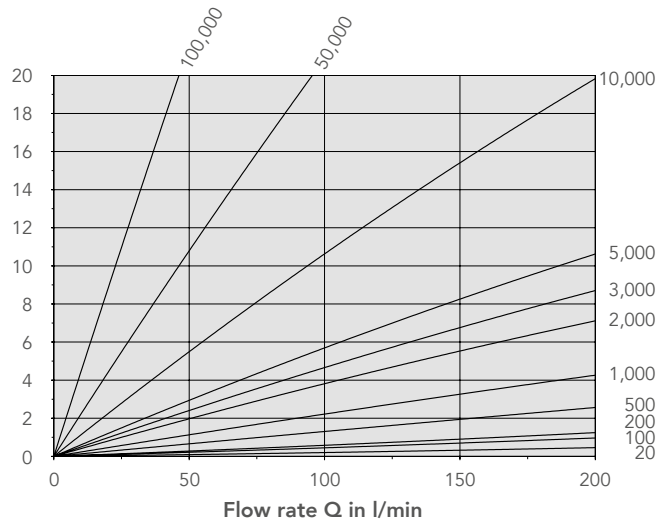

Pressure drop

I SVC 100 ... 250 Parameter: Viscosity in mm²/s

SVC 100

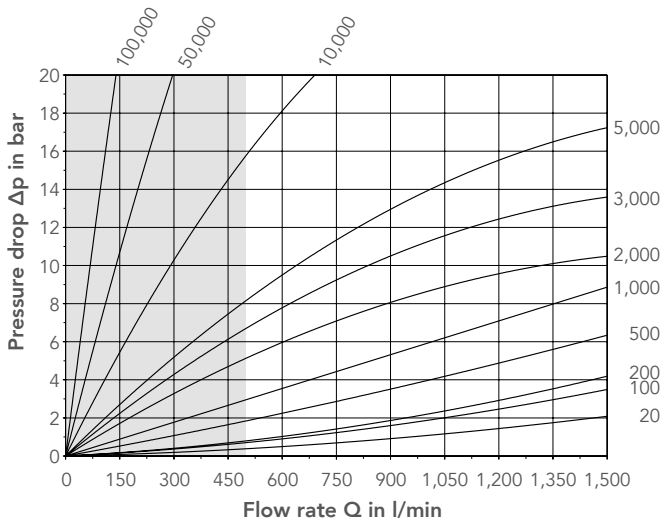

SVC 100 (section)

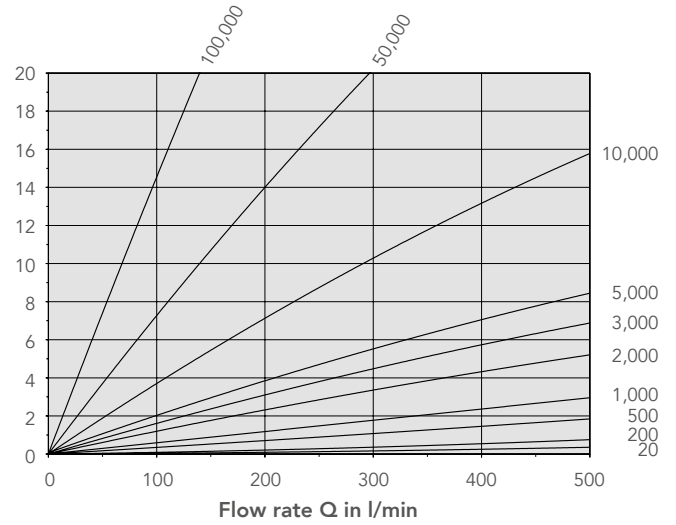

SVC 250

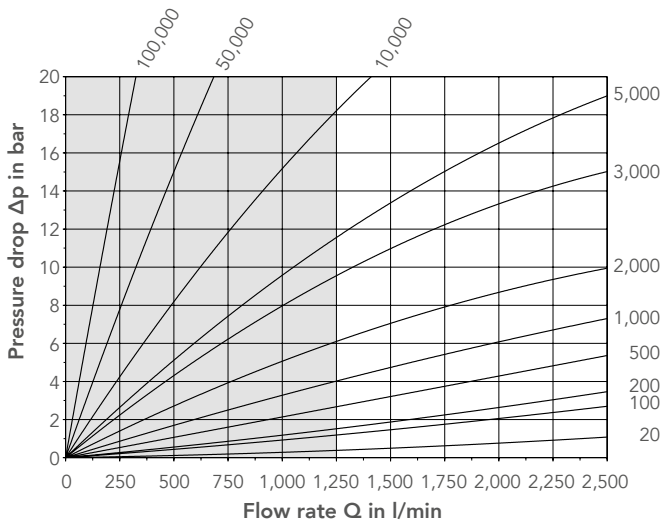

SVC 250 (section)

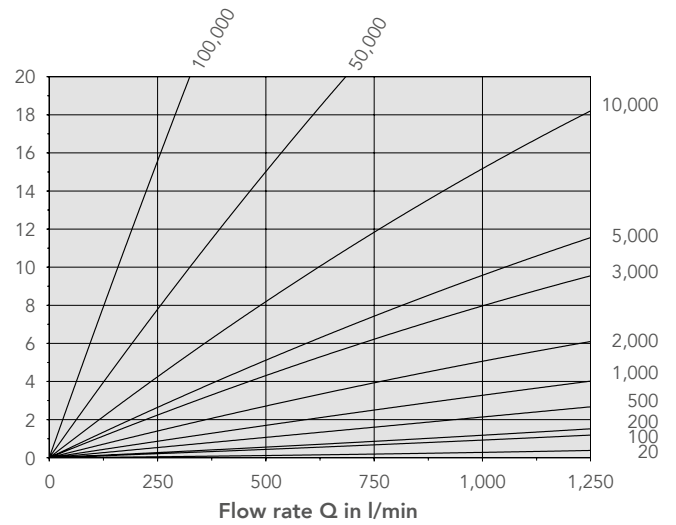

Technical drawings overview

Version	Nominal size	Electronic version	Page
High-pressure versions with high-res sensors	4	<ul style="list-style-type: none"> > Standard > High-temperature > ATEX/IECEEx > IO-Link 	17
High-pressure versions with high-res sensors	10	<ul style="list-style-type: none"> > Standard > High-temperature > ATEX/IECEEx > IO-Link 	18
2-sensor versions	10	<ul style="list-style-type: none"> > Standard > High-temperature > ATEX/IECEEx > IO-Link 	19
Versions with maximal sensor resolution	10	<ul style="list-style-type: none"> > Encoder 	20
2-sensor high-pressure versions	40	<ul style="list-style-type: none"> > Standard > High-temperature > ATEX/IECEEx > IO-Link 	21
2-sensor versions	40	<ul style="list-style-type: none"> > Standard > High-temperature > ATEX/IECEEx > IO-Link 	22
2-sensor versions	100	<ul style="list-style-type: none"> > Standard > High-temperature > ATEX/IECEEx > IO-Link 	23
2-sensor versions	250	<ul style="list-style-type: none"> > Standard > High-temperature > ATEX/IECEEx > IO-Link 	24
Remote-electronics versions	4 ... 250	<ul style="list-style-type: none"> > High-temperature Plus > ATEX high-temperature Plus 	On request

Dimensions

I SVC 4

Electronics versions: standard / high-temperature / ATEX/IECEX / IO-Link

Type key ID			Dimensions								Weight
Material	Connection	Sensor	A	B	D	L	H	G	P	X	
3	R	2	-	-	85	138	87.5*	G 3/4	-	30	4.7
3	S	2	50.8	23.8	85	138	87.5*	SAE 3/4	M10 - 22 deep	30	5.0

* Electronics version H: plus 3 mm

Pipe connection, high-pressure version, high-res sensor

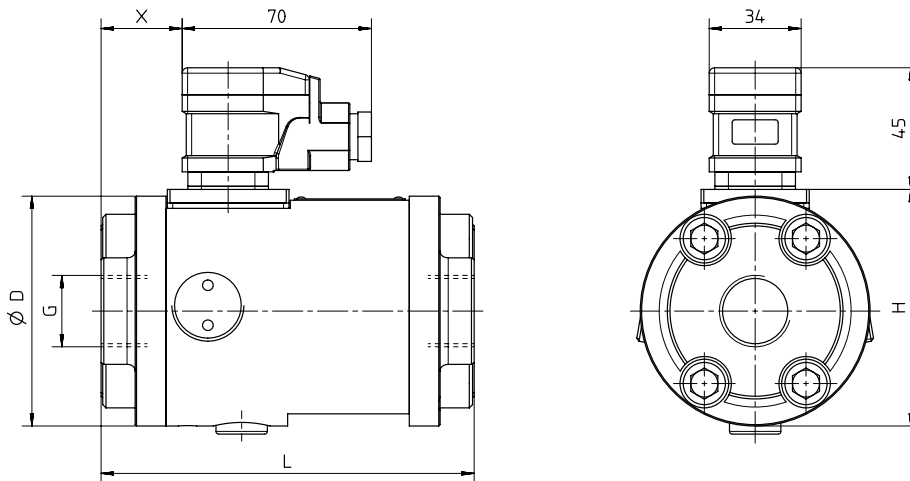

SAE connection (Code 62), high-pressure version, high-res sensor

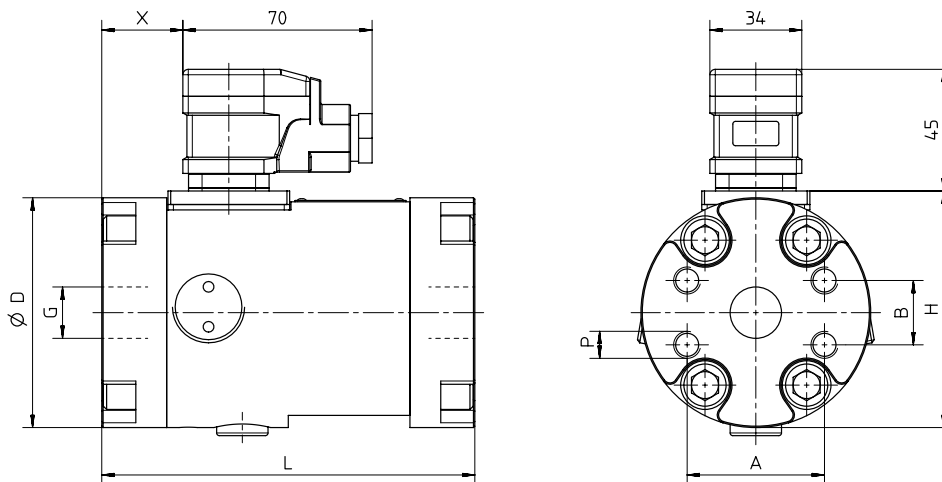

Dimensions

I SVC 10

Electronics versions: standard / high-temperature / ATEX/IECEX / IO-Link

Type key ID			Dimensions										Weight
Material	Connection	Sensor	A	B	D	L	K	H	G	P	T	X	
1	R	2	-	-	99	196	-	101.5*	G 1	-	19	33	9.6
1	S	2	52.4	26.2	99	197	-	101.5*	SAE 1	M10 - 17 deep	-	32	9.6
1	D	2	-	-	140	265	100	167.0*	32	M16 - 25 deep	-	76	17.2
3	R	2	-	-	110	213	-	107.3*	G 1	-	23	40	11.3
3	S	2	50.8	23.8	110	213	-	107.3*	SAE ¾	M10 - 15 deep	-	40	11.3

* Electronics version H: plus 3 mm

Available DIN flanges

Nominal bore DN	Pressure stage PN
32	40

SAE connection (Code 62), high-pressure version, high-res sensor

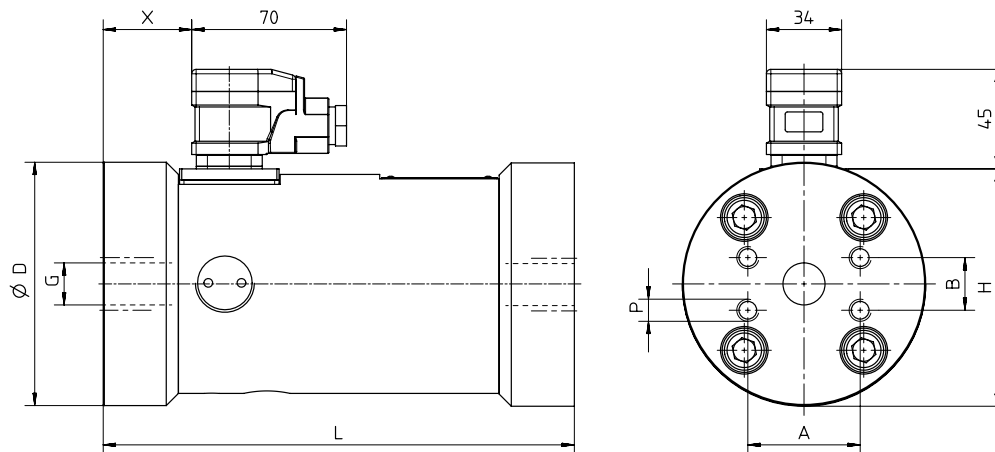

Pipe connection, high-pressure version, high-res sensor

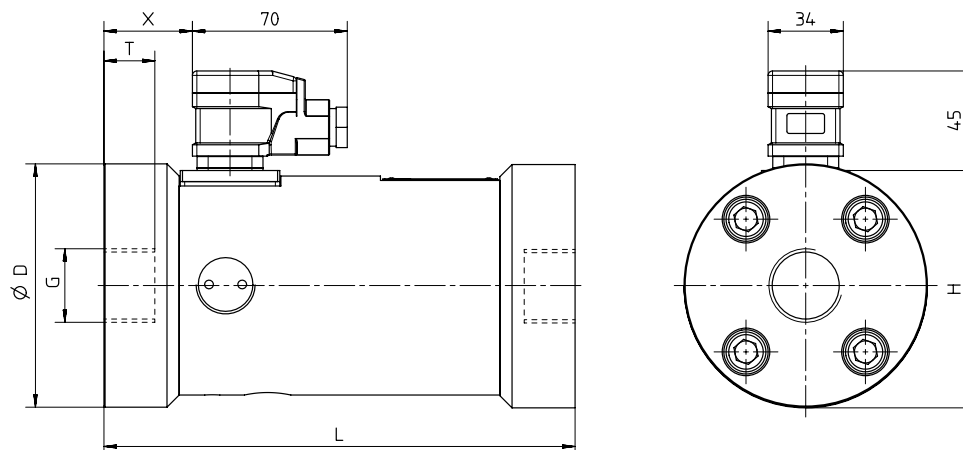

Dimensions

I SVC 10

Electronics versions: standard / high-temperature / ATEX/IECEX / IO-Link

SAE connection (Code 61), 2 sensors

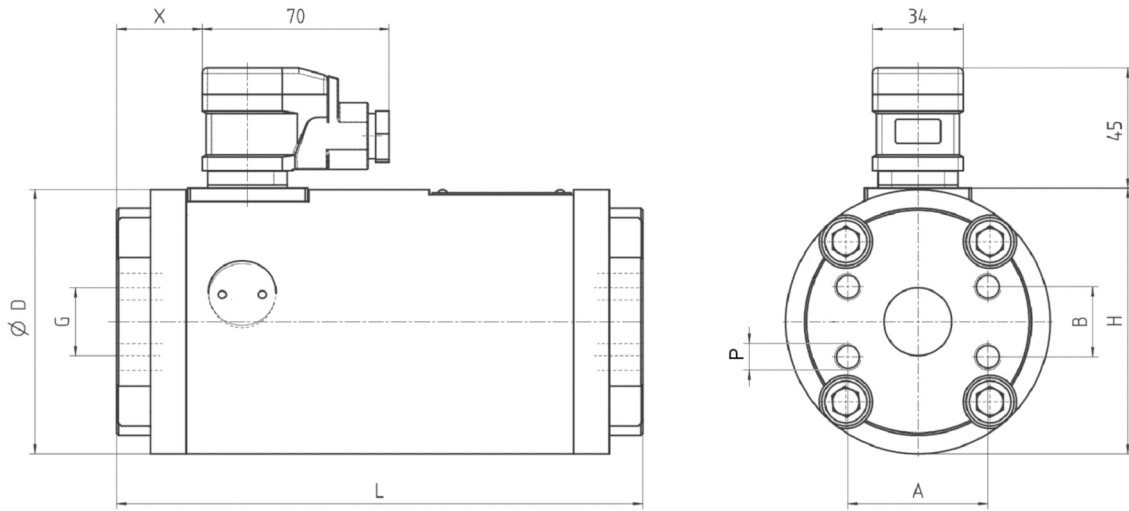

Pipe connection, 2 sensors

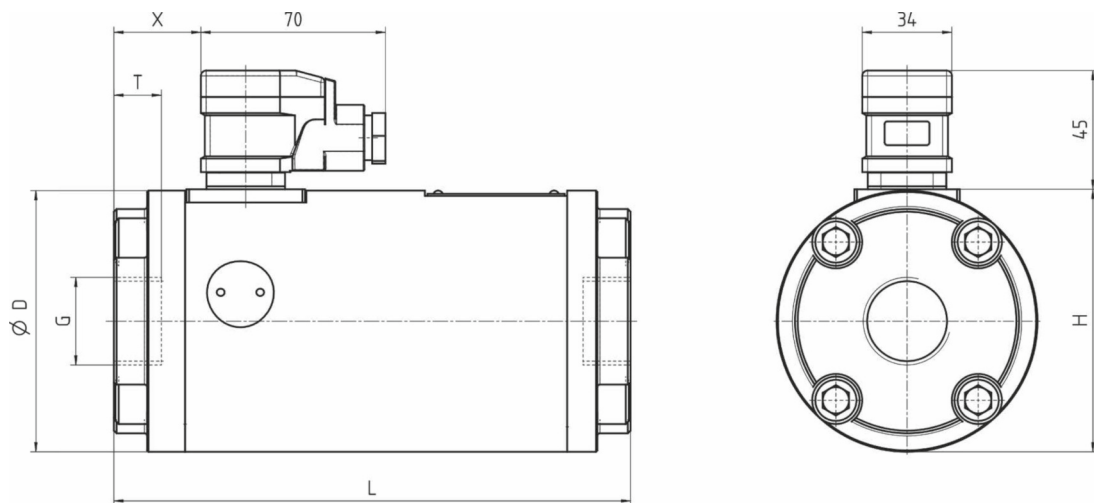

DIN connection, 2 sensors

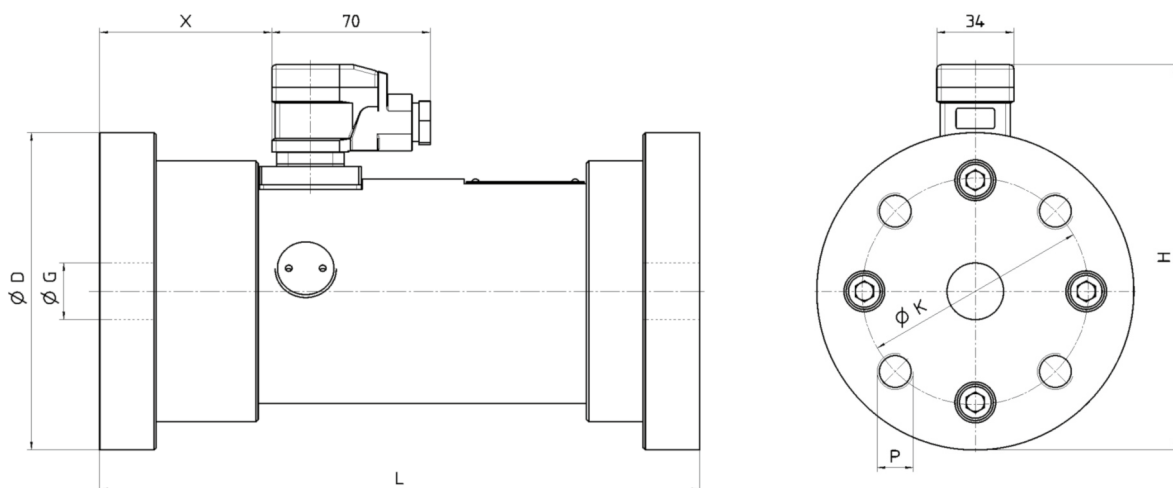

Dimensions in mm

Dimensions

I SVC 10

Electronics versions: encoder

Type key ID			Dimensions					
Material	Connection	Sensor	A	B	L	G	P	X
1	R	5	-	-	196	G 1	-	20.5
1	S	5	52.4	26.2	198	SAE 1	M10 - 17 deep	20.0

Pipe connection, maximal sensor resolution

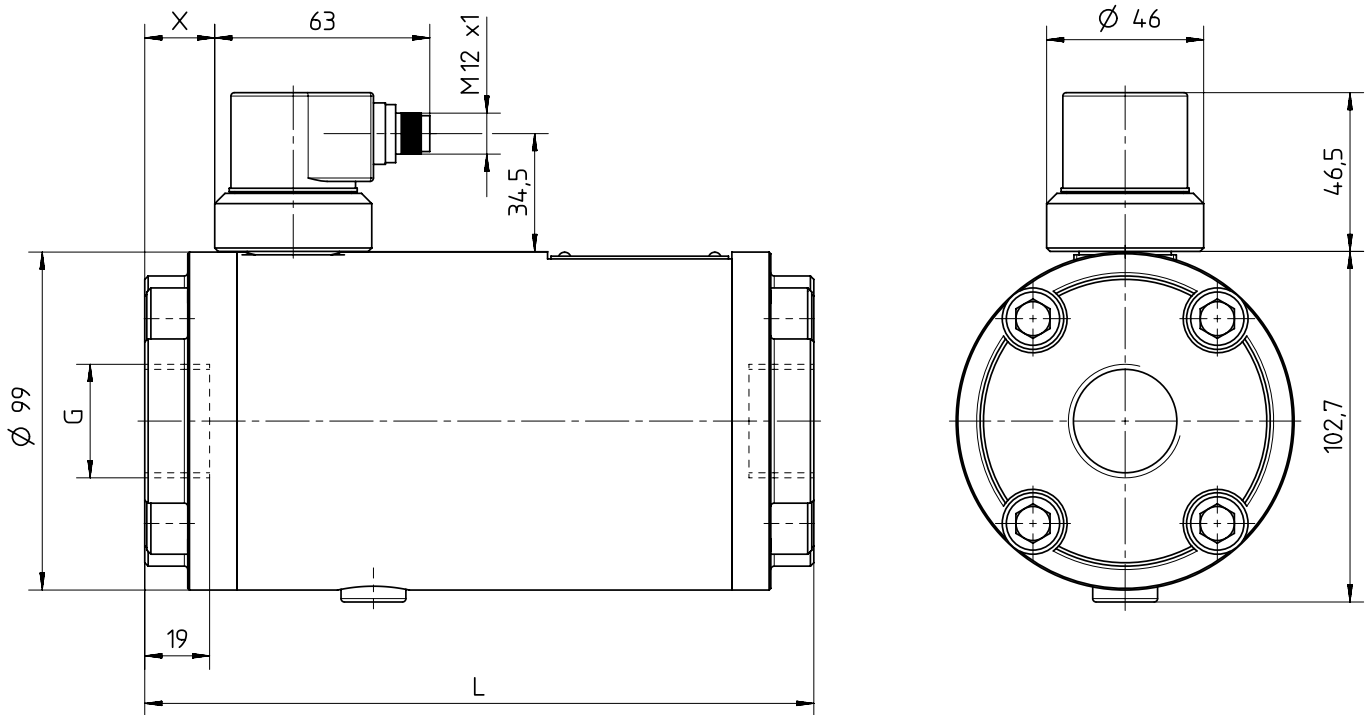

SAE connection (Code 61), maximal sensor resolution

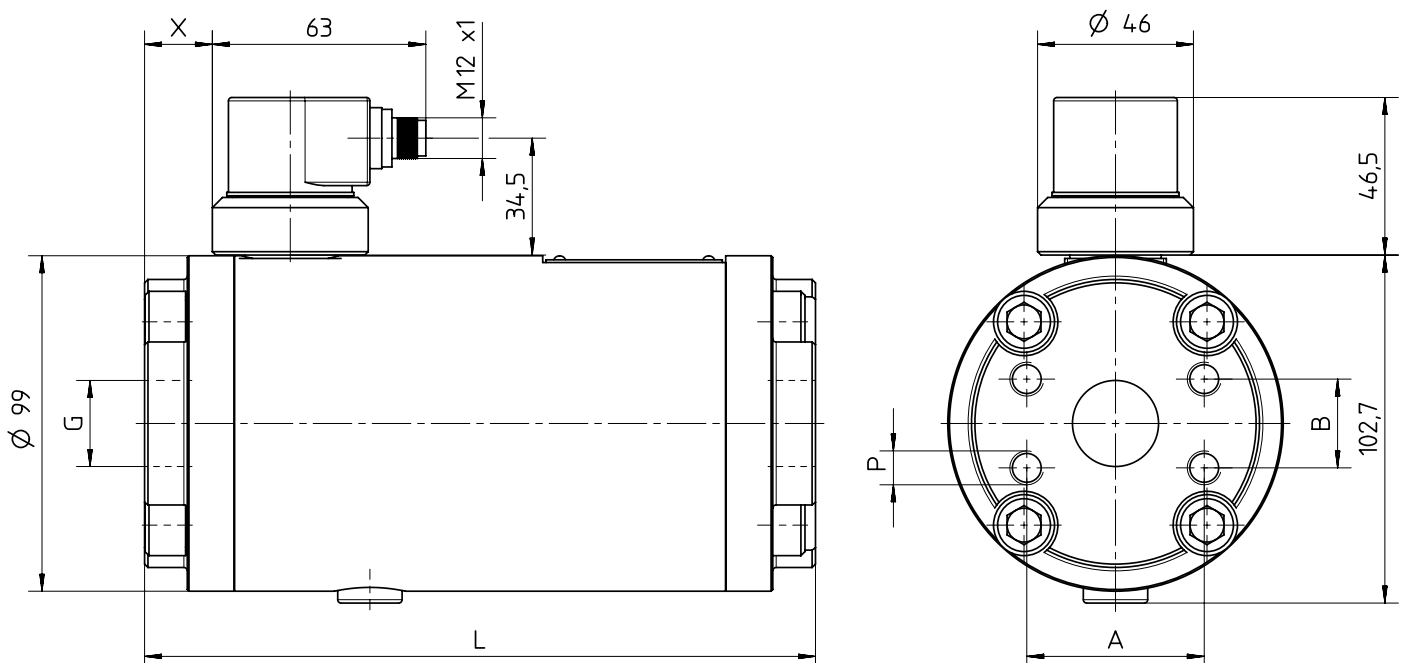

Dimensions in mm

Dimensions

I SVC 40

Electronics versions: standard / high-temperature / ATEX/IECEX / IO-Link

Type key ID			Dimensions										Weight
Material	Connection	Sensor	A	B	D	L	K	H	G	P	T	X	
1	R	2	-	-	121	265	-	123.5*	G 1½	-	23	26.0	18.0
3	R	2	-	-	155	307	-	198.5	G 1½	-	28	40.5	36.0
1	S	2	69.9	35.7	-	287	-	123.5*	SAE 1½	M12 - 27 deep	-	38.0	18.9
3	S	2	66.7	31.8	155	307	-	198.5	SAE 1¼	M14 - 27 deep	-	40.5	36.0
1	D	2	-	-	150	285	110	183.0*	40	M16 - 20 deep	-	37.0	24.7

* Electronics version H: plus 11 mm

Available DIN flanges

Nominal bore DN	Pressure stage PN
40	40

SAE connection (Code 62), high-pressure version, 2 sensors

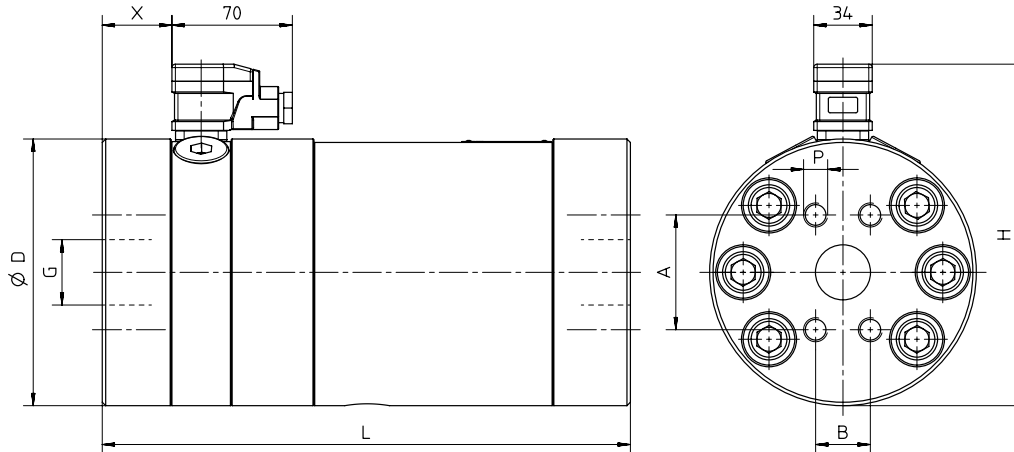

Pipe connection, high-pressure version, 2 sensors

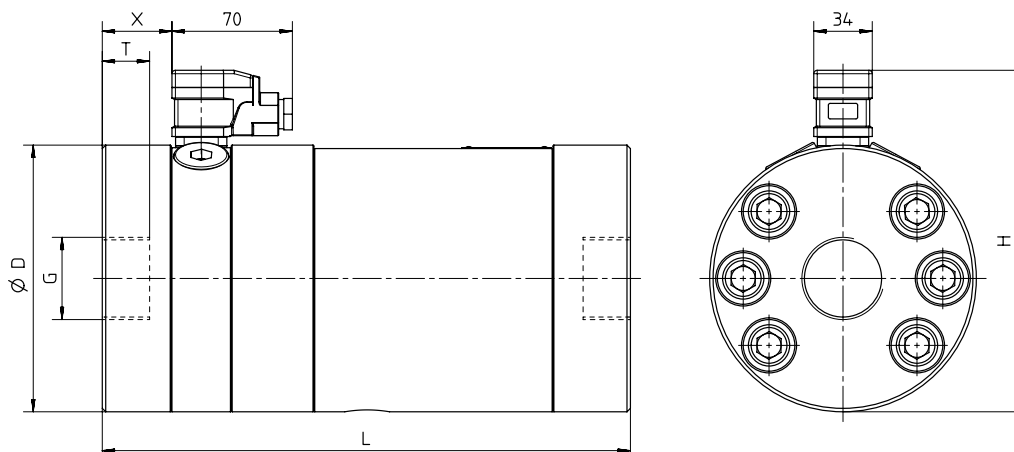

Dimensions

I SVC 40

Electronics versions: standard / high-temperature / ATEX/IECEX / IO-Link

SAE connection (Code 61), 2 sensors

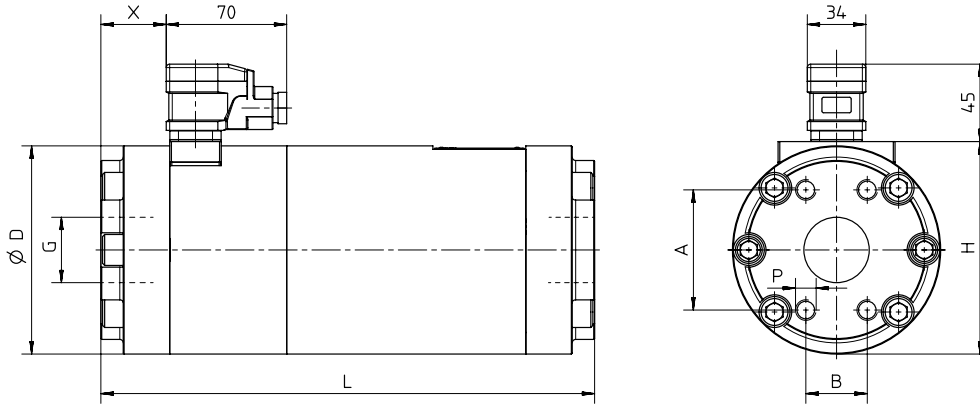

Pipe connection, 2 sensors

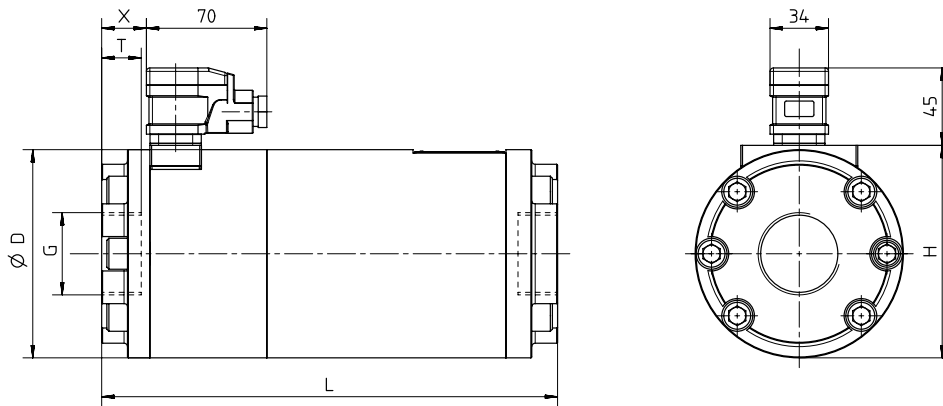

DIN connection, 2 sensors

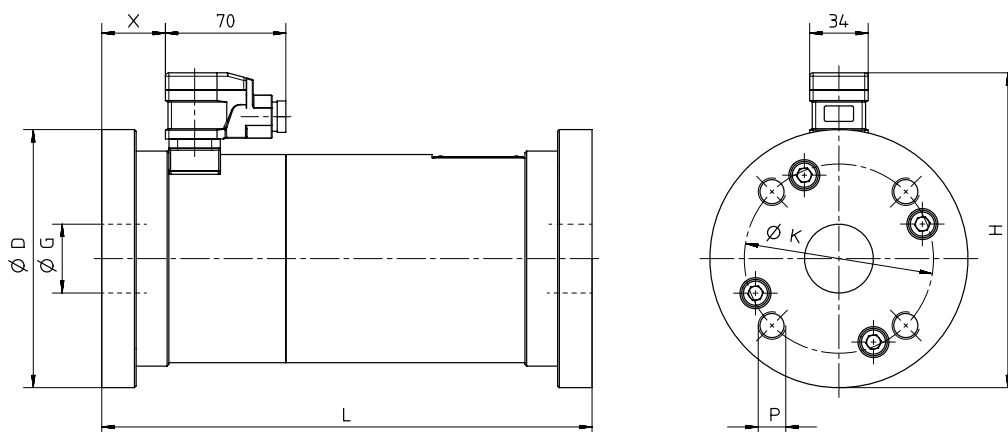

Dimensions

I SVC 100

Electronics versions: standard / high-temperature / ATEX/IECEX / IO-Link

Type key ID			Dimensions										Weight
Material	Connection	Sensor	A	B	D	L	K	H	G	P	T	X	
1	R	2	-	-	158	357	-	160*	G 3	-	32	30	39.1
1	S	2	106.4	61.9	158	347	-	160*	SAE 3	M16 - 32 deep	-	32	38.7
1	D	2	-	-	200	365	160	226*	80	M16 - 25 deep	-	45	46.2

* Electronics version H: plus 11 mm

Available DIN flanges

Nominal bore DN	Pressure stage PN
80	40

Pipe connection, 2 sensors

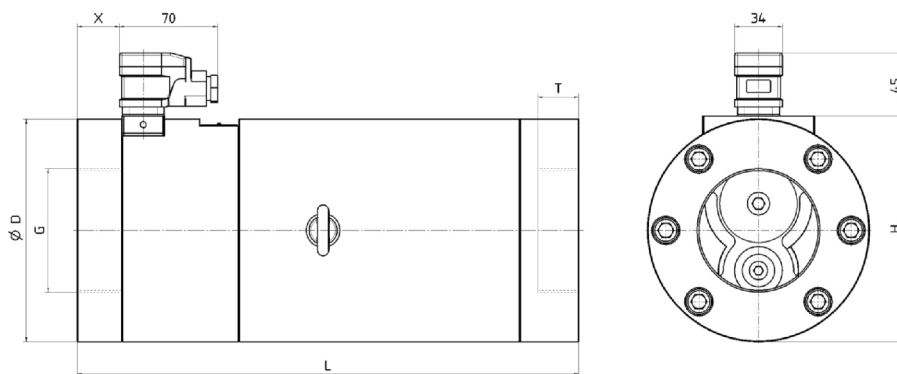

SAE connection (Code 61), 2 sensors

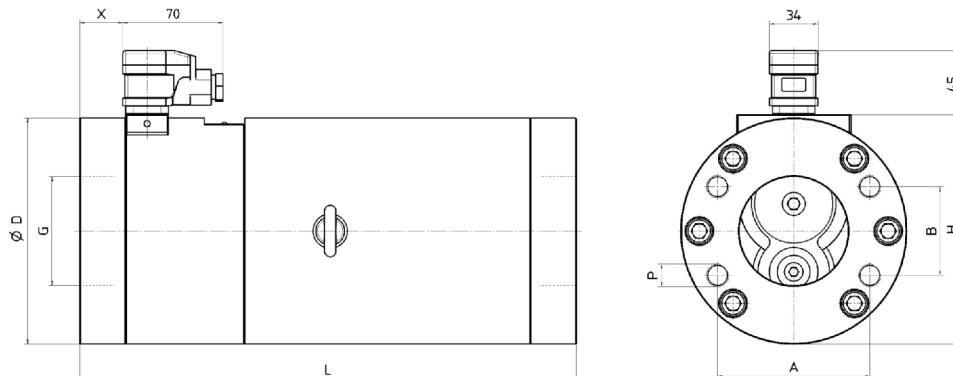

DIN connection, 2 sensors

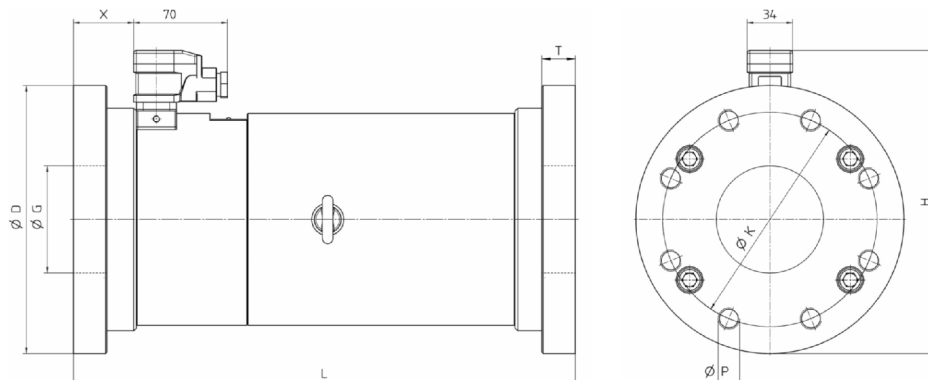

Dimensions

I SVC 250

Type key ID			Dimensions								Weight
Material	Connection	Sensor	A	B	D	L	H	G	P	X	
1	S	2	130.2	77.8	200	440	203*	SAE 4	M16 - 30 deep	37	76.0

* Electronics version H: plus 11 mm

SAE connection (Code 61), 2 sensors

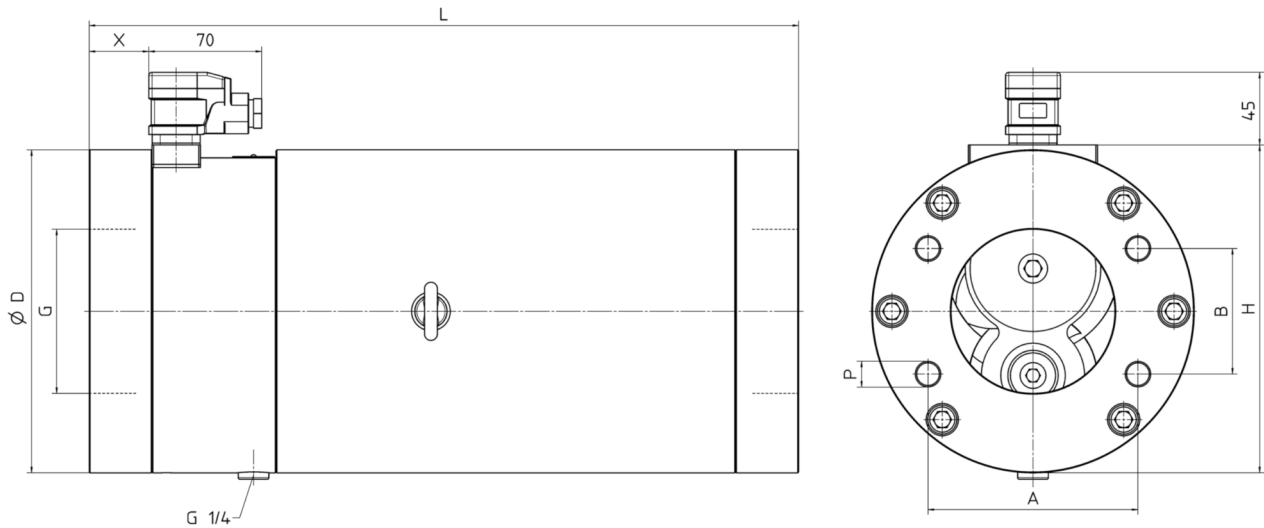

Notes

Notes

Notes

KRACHT[®]

KRACHT GmbH · Gewerbestrasse 20 · 58791 Werdohl, Germany
Phone +49 2392 935 0 · E-Mail info@kracht.eu · Web www.kracht.eu

SVC/EN/04.2024

Errors and technical changes reserved